

Kidde Fire Systems

Natura™ Inert Gas System

Component Description

Distance Pipe

FEATURES

- For Approvals, see the “COMPATIBILITY” table.
- REACH and RoHS compliant

DESCRIPTION

Use the distance pipe as a spacer when the front row of a cylinder rack has less cylinders than the rear row of the rack. Distance Pipes are only used on multi-row systems.

Note: Use together with clamping bolts:
P/N 01-8337-0200, 01-8337-0300, or
01-8437-0200

MATERIAL

Pipe: DIN 2440 Carbon Steel

Washer: ST 33

ORDERING INFORMATION

Part Number	Description
03-8331-0000	Distance Pipe 3/4 in. + Washers 80L
03-8331-0140	Distance Pipe 3/4 in. + Washers 140L



Figure 1.

COMPATIBILITY

Series	DIOM P/N	Approvals*
Natura™ Inert Gas System	06-237619-001	FM, UL

* For additional listings, contact Kidde Fire Systems

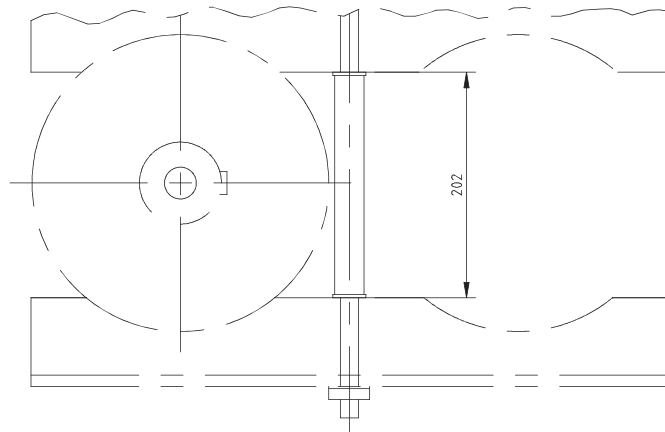
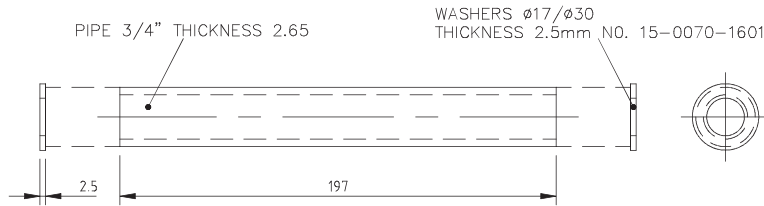

Figure 2. 80L Distance Pipe Dimensions

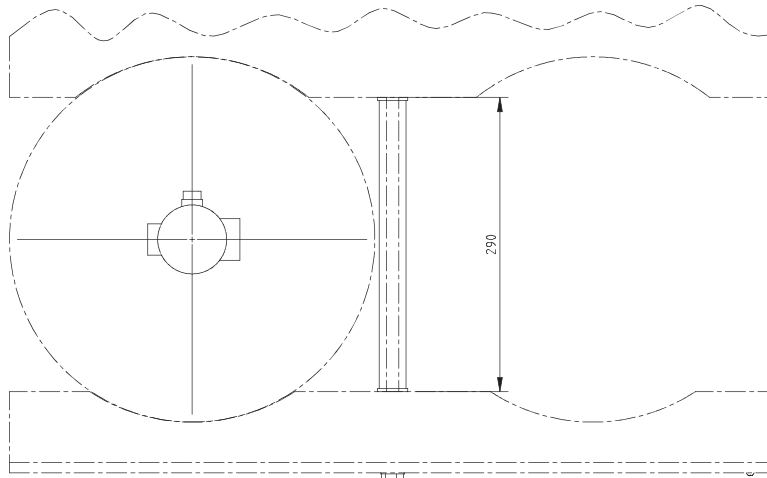
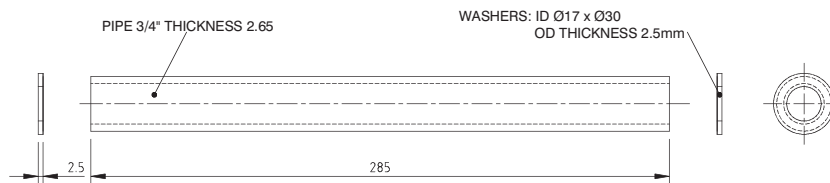

Figure 3. 140L Distance Pipe Dimensions

EXPORT INFORMATION (USA)

Jurisdiction: EAR

Classification: EAR99

This document contains technical data subject to the EAR.

All trademarks are property of their respective owners.

This literature is provided for informational purposes only. KIDDE-FENWAL, INC. believes this data to be accurate, but it is published and presented without any guarantee or warranty whatsoever. KIDDE-FENWAL, INC. assumes no responsibility for the product's suitability for a particular application. Product features specified are only applicable when the fire suppression system is correctly designed, installed, maintained and serviced by trained, authorized Kidde Fire Systems distributors as per the applicable design, installation, operation, and maintenance manuals. If you need more information on this product, or if you have a particular problem or question, contact: KIDDE-FENWAL, INC., Ashland, MA 01721 USA, Telephone: (508) 881-2000.